Well Inspection Report

Instructions

- Complete all pages.
- Sign and submit electronically within 30 days of the well inspection to orogo@gov.nt.ca.
- If you wish to submit a hard copy, please use the courier address at www.orogo.gov.nt.ca/contact-us.
- Refer to the [Well Suspension and Abandonment Guidelines and Interpretation Notes](#) (May 2022) for details on well inspection requirements.
- Report in metric units.

Required attachments:

- Photos of wellhead and well site (*Include descriptions*)
of photos attached: 5 Pictures
- Wellhead schematic
- Wellbore schematic

Well Information

Well name: I-73-60-10-117-15

4 digit WID: 1937

OROGO risk level: Level 2

Wellhead? Yes No

Pressure rating of all wellhead components: 900 / 1500 Ansi

Pumpjack? Yes No

Operator: Alvarez & Marsal Canada Inc., in its capacity as receiver of Strategic Oil & Gas's NWT Property
Well status: Suspended

Coordinates (*In decimal degrees; verified onsite*)
Datum: NAD 27 NAD 83 Unknown
Lat: 60.2' 44"
Long: -117.28' 24"

Completed in H₂S zone? Yes
 Estimated % of H₂S: 0.064 or
 Measured % of H₂S: 0

Inspection Date and Contact Information

Date of inspection: 2022-09-26

Date of previous inspection: 2020-10-29

Inspection conducted by:

Name: Kurt Hewitt
Company: K2H Consulting Ltd
Phone: 780-830-8303
Email: kurtw.hewitt@gmail.com

Environmental or Safety Concerns

(Report all incidents as required under section 75 of the Oil and Gas Drilling and Production Regulations)

Environmental or safety concerns? Yes No

If yes, provide details: [Click or tap here to enter text.](#)

Inspection Results

Site

Well site accessible for inspection and monitoring? Yes No

Equipment or debris on site? Yes No

Additional clean up required? Yes No

Provide details of all site accessibility concerns: This site is accessible with heavy equipment by winter access roads only, Year round access by Helicopter.

Brush cleared 25 m around wellhead?
 Yes No

Wind indicator present and functional?
 Yes No

Wellhead

Wellhead accessible for inspection and monitoring? Yes No

Valves chained and locked? Yes No

Valves operate freely? Yes No

Pressure test well head seal assembly?

Yes No

(If yes, provide details in comments section with supporting documentation)

Surface casing vent open, operable and accessible in all seasons? Yes No

Pumpjack secure? Yes No N/A

Visible marker or fence in place? Yes No
4-digit Well ID, operator and contact information up to date? Yes No

Date of previous well head seal assembly pressure test: [Click or tap to enter a date.](#)

Surface Casing Vent Flow (SCVF) / Gas Migration (GM) testing

Evidence of SCVF? Yes No

SCVF test conducted? Yes No

(If yes, provide details in comments section with supporting documentation)

Signs of GM? Yes No

GM test conducted? Yes No

(If yes, provide details in comments section with supporting documentation)

Gas samples taken? Yes No
(If yes, provide details in comments section identifying location and anticipated date of submission of analysis to OROGO)

Shut-in pressures

Production casing pressure (kPa):
109 PSI

Intermediate casing pressure (kPa):
[Click or tap here to enter text.](#)

Production tubing pressures (kPa):
390 PSI

Any other readings taken:
[Click or tap here to enter text.](#)

Comments

- Details of: SCVF/ GM testing (*Include source: SCV, wellbore or soil vapour*)
 Shut-in pressures (*Include equipment used, results, any changes from previous inspections and previous inspection dates*)
 Seal assembly testing (*Include maximum pressure tested and duration of test*)
 Other comments

10 minute Bubble test completed on SCV, no visible bubbles or flow indicated. See attached pictures for shut in pressures taken on Tubing and Casing. This well had a previous SCVF detected in October 2019 that was addressed in winter 2019. No H2S or LEL detected while on site.

Additional supporting documentation attached? Yes No

If yes, list attached documentation: Inspection Pictures

I certify based on personal knowledge of well inspection operations undertaken at the above named well that the above information is accurate.

Responsible Officer:

Date: 2022-10-14

Name: Duncan MacRae
Title: Vice President
Operator: Alvarez & Marsal Canada Inc., in its
capacity as receiver of Strategic Oil & Gas's
NWT Property

Signature:



I-73 Wellsite Inspection Pictures





Lat / Lon (GPS: ± 5 m)
60.045798
-117.475030
Elev: 775.731 m

Bearing: 83° (TN)

Sep 26, 2022 17:22:14



I-73 Wellsite

PARAMOUNT ET AL CAMERON I-73

60° 10' N, 117° 15' W

Bottom Hole Diagram (as of April 8, 2003)

KB: 779.27 m
GL: 774.80 m

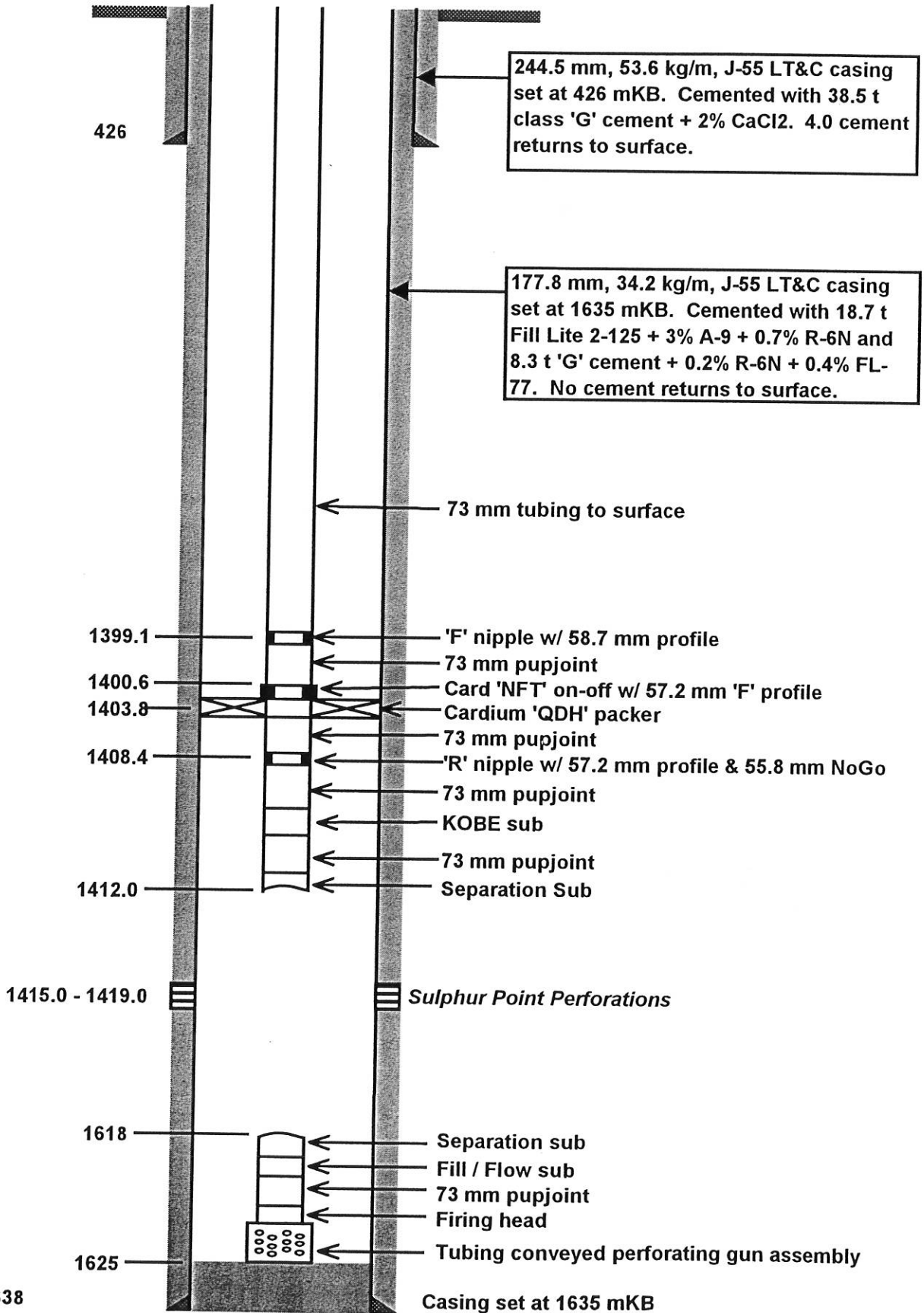

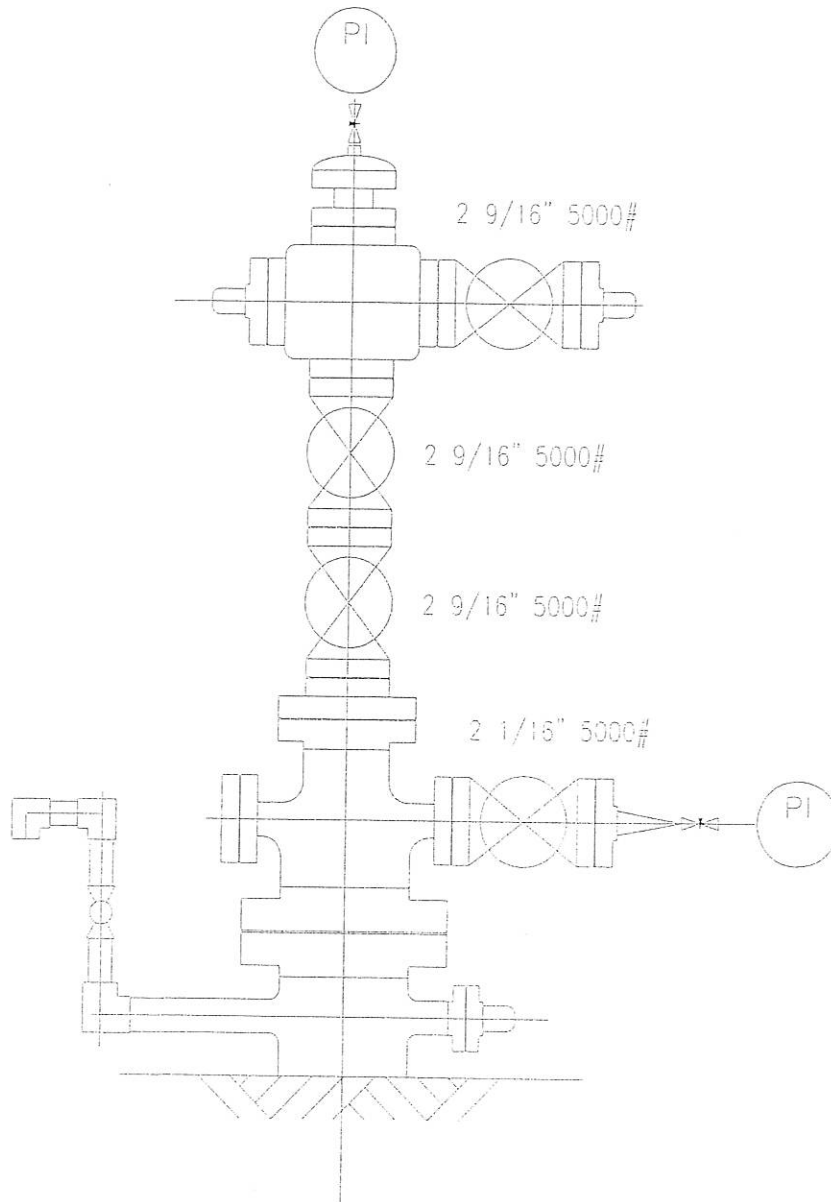

WELLHEAD DETAILS

WELL NAME _____
 LOCATION I - 73

Date: 090908
 By: KW
 Rev: A FOR INFO.

Wellhead
 Last Review Date